

Update notices for this book will be available online at www.actechbooks.com/revisions.html

VERSION	EFFECTIVE DATE	DESCRIPTION OF REVISION(S)
001	2020.03	Module creation and release.
001.1	2021.04	Enhanced Submodule 4; IFR 4000 and 6000 test equipment.
001.2	2021.10	Corrected description of file types (Submodule 7, pages 3.15-3.16).
001.3	2023.04	Inclusion of Measurement Standards for clarification, page iv. Minor appearance and format updates.
002	2024.07	Regulatory update for EASA 2023-989 Compliance.
002.1	2025.01	Page 5.9 - Corrected orientation of Figure 5-10B. Page 5.25 - Corrected y axis identifier for Figure 5-36.
003	2026.01	Regulatory update for EASA 2025-111. Submodule 7.4 added.
003.1	2026.03	Submodule 7.4 updated to meet new EASA 2025-111 guidance.

Potential Safety Hazards When Working With Electrical Systems And Protective Equipment

Submodule

4



SUBMODULE KNOWLEDGE DESCRIPTIONS		LEVEL
		B2
7.4	<p>Potential Safety Hazards When Working With Electrical Systems And Protective Equipment</p> <p>Electric Shock Hazards and effects of current on the human body. Arc flash/blast and stored energy hazards (capacitors, batteries, power electronics). Battery related hazards: chemical, thermal runaway, fire and explosion. Electrostatic discharge and electromagnetic hazards. Environmental and situational risks (wet conditions, confined spaces, poor accessibility). Protective measures: personal protective equipment, insulated tools, system isolation, verification of absence of voltage.</p>	3

7.4 POTENTIAL SAFETY HAZARDS WHEN WORKING WITH ELECTRICAL SYSTEMS AND PROTECTIVE EQUIPMENT

This submodule is about identifying and understanding electrical hazards such as arc flash and electric shock, establishing appropriate protection zones, the use personal protective equipment (PPE) and an isolation system known as lockout/tagout to warn team members that maintenance is in progress. By combining risk assessment, technology, procedures, and training, you can greatly reduce the risks to personnel and equipment when working with and around electrical systems.

ELECTRIC SHOCK HAZARDS AND EFFECTS OF CURRENT ON THE HUMAN BODY

Electric shock is defined as a sudden discharge of electricity through a part of the body. It occurs when an electric current passes through the body with the body becoming a part of the electric circuit. It can occur from contact with a live electrical source with the severity depending on the path of the current, the amount of current and the duration of the shock. [Figure 4-1] Injuries can range from minor pain and burns to severe internal damage, cardiac arrest or death.

Maintainers must be highly safety focused when operating and working on aircraft, aircraft electrical components or avionic components. By following established safety protocols, using appropriate protective equipment and tools, receiving proper training, understanding electrical systems, grounding equipment, maintaining and inspecting systems, and maintaining situational awareness, maintenance personnel can help prevent electrical accidents and ensure the safety of themselves and their fellow maintainers.

STATIC ELECTRIC SHOCK

Electrical shock in aviation often stems from static electricity buildup on the aircraft's surface caused by friction with air

particles. This can lead to discharges that can shock technicians or interfere with systems managed by static wicks and grounding. As this can cause a risk for maintenance crews, particularly during fueling, strict protocols, bonding, and specialized personal protective equipment can prevent serious incidents.

ELECTRIC SHOCK AND THE HUMAN BODY

The injury from electrical shock depends on the density of the current, tissue resistance and the duration of contact. Very small currents may be imperceptible or produce only a light tingling sensation. Even still, a shock caused by low and otherwise harmless current could startle an individual and cause injury due to jerking away or falling.

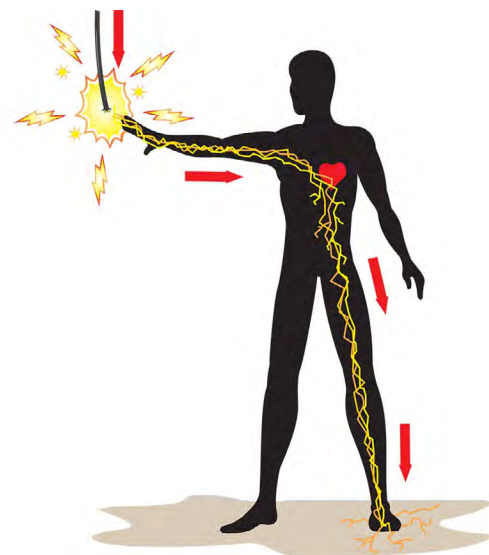

Figure 4-1. Electrical shock occurs when current flows through the body and into a conductive surface.

7.4 Potential Safety Hazards When Working With Electrical Systems And Protective Equipment

A strong electric shock can cause painful muscle spasms, sometimes severe enough to dislocate joints or even break bones. The loss of muscle control is the reason that a person may be unable to release themselves from the electrical source. If this happens at a height, you can be thrown off with injury resulting from that fall. Larger currents can also result in tissue damage and may trigger cardiac arrest. [Figure 4-2]

The electrical injury occurs upon contact of a body part with electricity that causes a sufficient current to pass through the person's tissues. Contact with energized wiring or devices is the most common cause. In cases of exposure to high voltages direct contact may not be necessary as the voltage may "jump" the air gap between the device and yourself.

A CASE STUDY

Injuries from electric shock can occur in many situations, including an unexpected contact with exposed terminals during routine maintenance. Awareness of this possibility is always necessary.

Transport Canada - December 2024: Two incidents have been reported in which maintenance personnel received electric shocks while carrying out maintenance on a Bombardier Challenger 605. The maintenance staff were injured when they came in contact with an exposed electrical connection on the baggage compartment heater thermostat. [Figure 4-3]

The terminals of the baggage compartment heater thermostat are located on the water tank forward access door, which is normally only accessed by maintenance personnel during maintenance activities.

Transport Canada service bulletin (SB) 605-21-006, was issued which provides instructions to apply adhesive sealant on the end terminals of the thermostat installed on the access panel door.

It is recommended that operators incorporate SB 605-21-006 across their affected fleet and for aircraft maintainers to exercise maximum awareness and caution while servicing Challenger 605 potable water tanks.

ARC FLASH, ARC BLAST, AND STORED ENERGY HAZARDS (CAPACITORS, BATTERIES, POWER ELECTRONICS)

ARC FLASH/ARC BLAST

An arc flash is a type of electrical explosion or discharge that results from a low impedance connection through the air to ground or to another voltage phase in an electrical system. This phenomenon occurs when an electric arc causes a sudden release of electrical energy due to a fault. [Figure 4-4]

The significance of an arc flash when maintaining electrical equipment cannot be overstated. It poses a serious risk to workers and equipment in any environment where electrical systems are present. Arc flashes result in a bright flash and intense heat, leading to fires, explosions and severe injury or even death to nearby personnel. An arc flash can generate temperatures over 19 000°C, being several times hotter than the surface of the sun. An accompanying arc blast often occurs with the flash as a result of the sudden release of pressure during the flash event. [Figure 4-5]

Common injuries due to arc flash include:

- Severe burns: The intense heat can cause second and third degree burns, even from meters away and can ignite flammable clothing.
- Blast injuries: The pressure wave can cause blunt force trauma, broken bones, concussions, and internal injuries. It can also propel molten metal and other debris at high speeds.
- Other injuries: The bright flash can cause eyesight damage or blindness. The loud noise can lead to permanent hearing loss. Inhaling hot gasses and vaporized metals can cause respiratory issues. Implementing safety measures such as proper personal protective equipment (PPE), and thorough training can help mitigate these risks.

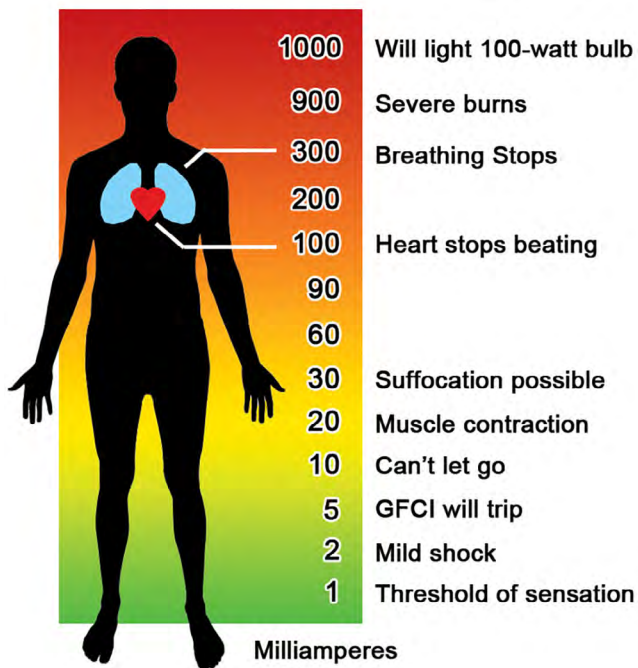

Figure 4-2. The energy of electrical shock is typically expressed in amperes and milliamps. This chart shows the typical effects at various levels.

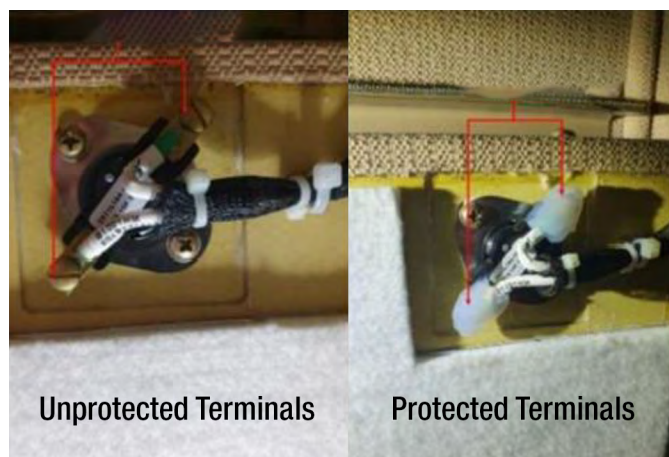

Figure 4-3. Following multiple injuries, exposed terminals (left side) are directed to be protected with an adhesive non-conducting sealant.

CAUSES OF ARC FLASH

Arc flashes are often the result of equipment failure, environmental factors and human error. For example:

- Accidental contact with energized components, often from dropping tools or using improper testing procedures.
- Equipment failure due to aging infrastructure, damaged insulation, or loose connections.
- Environmental factors like conductive dust, moisture, or corrosion creating an alternate path for the current.
- Improper work practices, such as failing to de-energize equipment or not using proper lockout/tagout (LOTO) procedures.

EQUIPMENT FAILURE

Equipment failure can lead to these dangerous arc flash events due to:

- Deterioration over time
- Faulty installation or maintenance
- Component malfunction
- Inadequate ratings
- Contamination



Figure 4-4. The dangers of arc flash can not be understated.

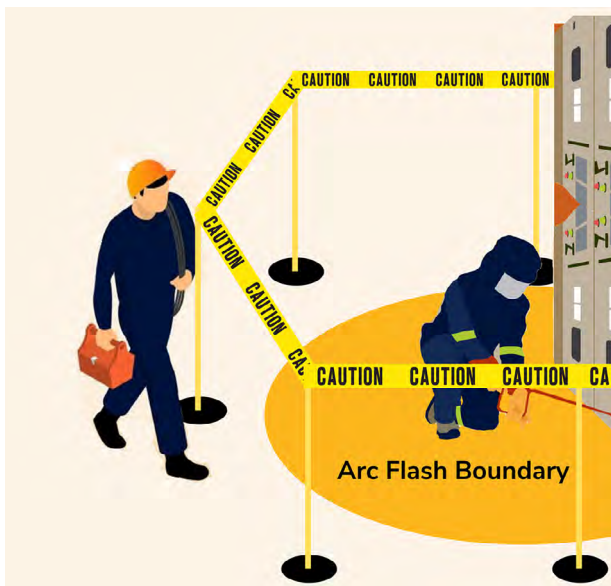

Figure 4-5. Setting up boundary areas when arc flash is possible will help reduce the risks of heat and arc blasts to unprotected personnel.

ENVIRONMENTAL FACTORS

Environmental factors like dust, corrosion, and condensation can significantly increase the risk of arc flashes.

1. **Dust:** Dust accumulation on electrical equipment can create a conductive path leading to short circuits and arc flashes. Dust can also insulate heat, causing equipment to overheat and fail.
2. **Corrosion:** Corrosion degrades the integrity of electrical components, compromising insulation and increasing the likelihood of electrical faults. This can result in arc flashes, especially in environments with high humidity or exposure to corrosive substances.
3. **Condensation:** Moisture from condensation can bridge gaps between conductors, creating unintended electrical paths. This can lead to short circuits and arc flashes, particularly in poorly ventilated or temperature variable environments.

Regular maintenance and inspections are crucial in preventing arc flashes. Routine checks help identify and address potential issues like dust buildup, corrosion, and moisture before they lead to dangerous situations. Ensuring that all electrical equipment is in good working condition reduces the risk of faults and enhances overall safety.

HUMAN ERROR

Human error is a significant contributing factor to arc flash incidents, often due to a lack of knowledge, inadequate prevention, training or complacency. Human error can lead to dangerous arc flash events do to:

- Inadequate Training
- Ignoring Safety Protocols
- Mistakes in Judgment
- Accidental Contact
- Improper Use of Tools and Equipment
- Failure to De-Energize Equipment
- Complacency

PREVENTION OF ARC FLASH

Preventing equipment failure through regular inspections, proper installation, maintenance and using only components that meet the necessary specifications such as current limiters are critical steps in mitigating the risk of arc flash incidents. Some equipment types that commonly fail and lead to arc flash incidents are:

- Circuit breakers
- Transformers
- Switchgear
- Panel boards and switchboards
- Motor control centers
- Disconnect switches
- Cables and wiring
- Relays

The best way to prevent an arc flash is to de-energize electrical equipment before working on it. When this is not feasible, safety measures must be implemented such as:

- **Reducing Fault Current:** Use current limiting devices such as fuses and circuit breakers to minimize the amount of current available in the system.

- **Limiting Arc Duration:** Install arc flash protective relays which use light and current detection to rapidly interrupt a fault. Use zone selective interlocking to enable the breaker closest to a fault to trip faster, which so reduces the total arcing time.
- **Compartmentalize and Isolate:** Design electrical systems with physical barriers between bus bars, cable connections, and other energized components to prevent the propagation of an arc fault and inadvertent contact.
- **Remote Operation:** Operate breakers remotely to keep personnel outside the arc flash hazard boundary during high risk operations, such as switching circuit breakers or inserting breakers into a live bus.
- **Digital Monitoring:** Implement continuous thermal monitoring sensors to monitor equipment health remotely, reducing the need for workers to open panels on energized equipment for inspections.
- **Regular Maintenance:** Conduct routine inspection programs to identify and address common causes of equipment failure, such as worn insulation, loose connections, dust buildup, or corrosion.

STORED ENERGY HAZARDS

Stored energy hazards refer to the unexpected release of energy from machinery or systems after the main power source is turned off. Examples may include springs, compressed air, hydraulic fluid pressure, or as relevant to this submodule, electrical capacitors, batteries, and powered electronics. The proper lockout/tagout procedures as discussed later in this submodule are key to the prevention of these releases.

CAPACITORS

Capacitors pose hidden hazards because they store large amounts of electrical energy even after equipment is de-energized, leading to potentially fatal electric shocks and arc flash. Key risks include unexpected discharge, thermal failure, and toxic chemical leakages, making safe handling and proper discharging essential. [Figure 4-6]

The primary hazards from capacitors include:

- **Electric Shock (possibly fatal):** A capacitor can retain its electrical charge for long periods, releasing it in microseconds. A capacitor's charge is often measured in Joules. At this scale even a 1 Joule release can cause a painful shock, while a 10 Joule release can trigger cardiac fibrillation, and a 50 Joule charge being often fatal.
- **Arc Flash/Blast:** A damaged, overcharged, or shorted capacitor can explode, releasing hot gases, flames, and metal debris. In an electrical bank, one capacitor failure can trigger a cascade of explosions.
- **"Lurking" Residual Energy:** A circuit may seem safe after being powered off, but capacitors downstream can remain charged, often bypassing standard voltage checks. Note that some large capacitors can self-recharge after initially being discharged. This occurs when a capacitor recovers a portion of its original voltage over minutes or hours. Always insure that a capacitor's terminals are kept shorted during storage.
- **Thermal Damage & Fire:** Overheating from high current, improper soldering or reversed voltage can cause capacitors to catch fire, vent, or fail violently.

- **Chemical Hazards:** Electrolytic capacitors contain toxic or caustic fluids that can leak, causing skin irritation or environmental damage.

Safety precautions when handling capacitors include:

- **Discharge Before Touching:** Use a properly rated discharge tool or a high resistance resistor to bleed the charge before touching the terminals.
- **Verify with a meter:** Never assume a capacitor is empty. Always verify zero voltage with a meter. [Figure 4-7]
- **Proper Storage:** For long term storage or maintenance, keep terminals physically shorted with a wire or bar to prevent self-recharging.
- **Visual Inspection:** Look for bulging cases, leakage, or burn marks before handling.
- **Wear PPE:** Use insulated gloves, safety glasses and arc rated clothing when working with capacitors or other high voltage systems.

BATTERIES

Storing energy in batteries presents several physical and chemical hazards, primarily stemming from the risk of an uncontrolled energy release. Primary hazards include:

- **Thermal Runaway:** This is a self-sustaining chain reaction where a battery cell generates heat faster than it can dissipate it. This often leads to intense fires which can burn for days and/or explosions if the expanding gasses are confined in enclosed spaces such as battery boxes.



Figure 4-6. Capacitors are found throughout an aircraft. These depict those of a typical strobe light unit.

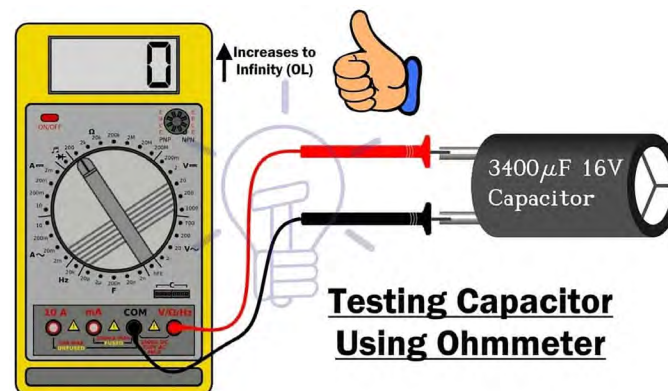

Figure 4-7. An Ohmmeter or multimeter's probes are connected to each capacitor terminal. If the reading is zero, the capacitor is free of any residual charge.

- **Toxic Gas Emissions:** During a failure or fire, batteries release a cocktail of harmful gases, including hydrogen fluoride, carbon monoxide and hydrogen cyanide.
- **Stranded Energy:** Even after a fire is seemingly extinguished, damaged batteries can retain a significant electrical charge with no safe way to discharge it.
- **Electrical Hazards:** Arcing from high voltage systems (typically 50V plus) can cause electrical burns or electrocution.
- **Corrosivity:** Electrolytes in many batteries are corrosive and can cause chemical burns to skin or eyes upon leakage.
- Several factors can cause battery failures including:
 - **Mechanical Abuse:** Physical damage such as crushing, dropping, or puncturing the battery.
 - **Electrical Abuse:** Overcharging, over-discharging, or external short circuits.
 - **Thermal Abuse:** Exposure to extreme external temperatures, both hot and cold.
- **Environmental Factors:** Flooding, high humidity, or debris ingress such as dust or salty fog can compromise internal components.
- **Manufacturing Defects:** Internal short circuits caused by poor quality control or contaminants introduced during production.

Best mitigation and safety practices need to be observed to avoid battery related mishaps. First is the inclusion of an approved battery management system which is capable of monitoring voltage, current and temperature, and is self capable of shutting the system down before failure occurs.

Second regards proper storage. Batteries should be stored at room temperature in well ventilated dry areas and away from flammable materials. For lithium-ion batteries, a charge level somewhat below 50% is often recommended for long term storage.

POWER ELECTRONICS

As powered electronic units often contain capacitors, inductors and batteries, they must be treated in the same way as with the above individual components which can maintain their charges for long after they are disconnected from a power source. Always ensure that any residual charge is fully dissipated prior to disconnection or disassembly. Always handle and store devices in a gentle and acceptable manner. And, always employ proper lockout/tagout procedures during maintenance.

BATTERY RELATED HAZARDS: CHEMICAL, THERMAL RUNAWAY, FIRE AND EXPLOSION RISKS

Battery safety, beyond the precautions discussed above requires the additional understanding of the hazard of thermal runaway. Thermal runaway, as prevalent mostly in regards to lithium-ion batteries is an uncontrollable, self accelerating chain reaction where an increase in temperature changes conditions in a way that causes a further increase in temperature.

This positive feedback loop occurs when a system generates heat at a rate significantly higher than it can dissipate to its surroundings. As internal chemical reactions, get hotter, they release more energy

which further releases thus more heat energy, often reaching temperatures above 600°C within minutes. In a battery bank of multiple cells, this intense heat from a single failed cell can then spread to adjacent cells leading to the runaway condition throughout the entire battery pack. [Figure 4-8]

A number of conditions can lead to a thermal runaway. Physical damage to the battery such as punctures or crushing can cause internal short circuits. Electrical abuse such as overcharging or deep discharging can lead to an overheat condition, as could a general failure of the battery's cooling system. In addition manufacturing flaws such as impurities or poorly made separators can lead to failures over time.

STAGES OF A THERMAL EVENT

A thermal event generally follows a specific sequence of internal degradation.

1. The solid-electrolyte interphase layer begins to break down. (~70°C–120°C).
2. Anode/Electrolyte reactions begin to occur when exposed lithium reacts with the electrolyte generating gasses and more heat. (~100°C–120°C).
3. Separator Melting: The physical barrier between the anode and cathode melts, causing an internal short circuit. (~130°C–150°C).
4. Cathode Decomposition: The cathode material breaks down, releasing oxygen that fuels intense combustion and possible explosion. (~150°C–200°C+).

Beyond user errors such as physical abuse and poor charging practices, thermal runaway can be controlled through a battery management system (BMS). A BMS is a standard component within a battery pack system which monitors certain conditions and if exceeded will shut the system down before damage can occur. [Figure 4-9]

The additional prevention strategies employed by the battery manufacturer include the use of fire resistant barriers such as Aerogel placed between cells to prevent heat spread. In addition, battery chemistries are constantly improving which have a higher tolerance of heat as the onset of runaway. An example is the use of lithium iron phosphate as a replacement for the previous nickel manganese cobalt chemistries.

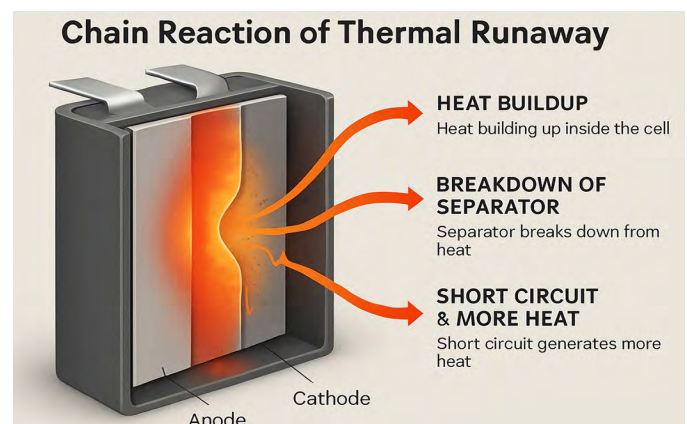

Figure 4-8. Thermal runaway begins with heat buildup between the cathode and electrolyte, breaking down the separator and thus generating more heat.

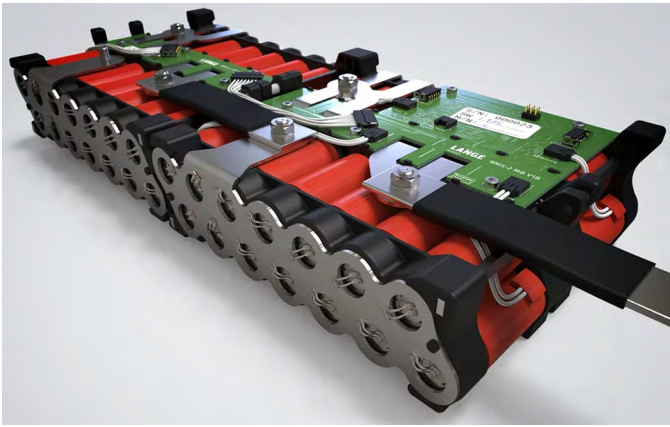

Figure 4-9. A battery pack with management circuitry from Lange Aviation.



Figure 4-10. Grounding an aircraft (of any type) is a critical step during all fueling or defueling procedures.

ELECTROSTATIC DISCHARGE (ESD) AND ELECTROMAGNETIC HAZARDS

ELECTROSTATIC DISCHARGE (ESD)

Electrostatic discharge (ESD) is the sudden release of static electricity when two objects with different electrical potentials make contact or come close to each other. While often perceived as a harmless "zap", ESD presents significant hazards in aviation environments, ranging from invisible electronic damage to catastrophic explosions.

FIRE AND EXPLOSIONS

The risks of fire due to an ESD discharge are particularly high during the transfer of fuels. As fuels are poor conductors, they can accumulate large charges causing sparking and the resultant fire. As a preventative measure, it is critical to always ground both the aircraft and fuel dispensers while fueling or defueling an aircraft. [Figure 4-10] More on the fueling/defueling procedure is presented in submodule 17 of this book.

Static electricity, even a single spark, can also ignite airborne dust and flammable gas mixtures during various maintenance operations. For this ignition to occur, a charge must be generated either by friction or a triboelectric effect, allowed to accumulate and then discharged into the atmosphere.

DAMAGE TO ELECTRONICS

Electrostatic discharge is the leading cause of failure for integrated circuits and other sensitive equipment. The most vulnerable components being microchips, MOSFET transistors, capacitors and magnetic storage media as are often found in all avionics equipment and computing devices, some of which can be destroyed by as little 10 volts. [Figure 4-11]

Failure types can be either catastrophic due to the immediate breakdown of electronic junctions or can be latent whereby a component is weakened to the point where it will pass an initial test, only to later fail later during operation.

For more on the prevention of ESD damage to electronic equipment, see module 5, submodule 12 of this Aviation Maintenance Certification Series.

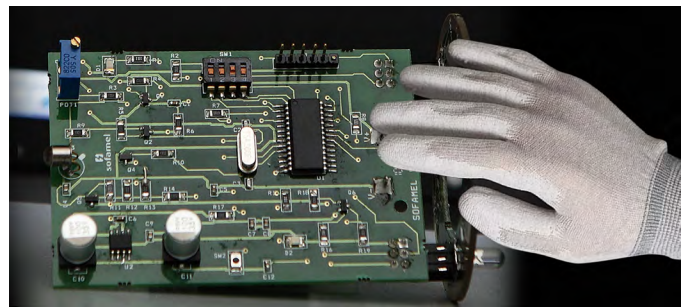

Figure 4-11. Electronic equipment is extremely sensitive to ESD, necessitating careful procedures, even when only in close proximity to the device.

PERSONAL SAFETY

While an ESD shock by itself is rarely life threatening, the involuntary recoil or muscle contraction from the surprise zap can cause a technician to fall or drop sensitive equipment. However, during more extreme cases if batteries or high voltage equipment is involved, an ESD event can lead to electrocution or severe burns. In addition an ESD event can interfere with the function of medical devices such as a pacemaker.

ELECTROMAGNETIC HAZARDS

Hazards in aviation primarily involve electromagnetic interference, which can disrupt critical flight systems, and ionizing radiation, which poses health risks to crew and passengers.

Electromagnetic interference refers to electrical signals that interfere with the performance of avionics and is typically categorized by its source, either external, internal, or natural. External sources, known as high intensity radiated fields (HIRF), can come from radio transmitters, radar and other types of transmitted fields. Internal sources such as cell phones and other personal electronic devices, while lower powered, can interfere with certain systems such as GPS reception and radar altimeters. Natural phenomena such as lightning can cause direct damage and electrical surges. Solar flares leading to increased radiation levels can corrupt data in flight computers sometimes causing navigational errors. HIRF is additionally covered in submodule 19 of this book.

Radiation hazards from cosmic rays are more prevalent at higher altitudes where the protective atmosphere is thinner, but during times of increased solar activity can affect systems all the way to the ground. Due to this pilots and cabin crew are classified as "radiation workers" because their annual exposure is high, sometimes even exceeding that of nuclear power plant workers. For passengers and occasional flyers, because the dose is only occasional, the long term risk is less being comparable to a chest x-ray during the time of an extended flight.

To help protect against electromagnetic hazards, modern aircraft designs include metal skins, conductive gaskets, and/or other systems of shielded wire to help block signals. Additional design certifications such as EUROCAE ED-14 and the American equivalent RTCA/DO-160 must be complied with during the design and manufacturing phases and so become a part of maintenance concerns throughout the life of the aircraft.

ENVIRONMENTAL/SITUATIONAL RISKS

WET CONDITIONS

Wet conditions create increased electrical hazards because water, especially when impure, is an excellent conductor that significantly reduces skin resistance, increasing the risk of electrocution, shock, and fires.

Essential safety measures include using Ground Fault Circuit Interrupters (GFCI), keeping electrical and electronic devices at least 3 meters away from water, using waterproof rated equipment, and avoiding contact with circuits while wet or standing in water.

Aircraft GFCIs are devices designed to detect leakage currents, as low as 5 milliamperes. When leakage is detected, the GFCI will break the circuit within milliseconds to prevent shock or fire. These devices are found throughout the aircraft but in particular in known wet zones such as lavatories and galleys. Aircraft rated GFCIs differ from standard circuit breakers by focusing on current imbalances rather than just overloads. [Figure 4-12]

CONFINED SPACES

Electrical hazards increase when working in confined spaces such as wheel wells, equipment bays, or fuel tanks. In confined spaces, these risks are amplified by limited space for maneuvering, a greater potential for explosive atmospheres, and difficulty in rescue. When working in such environments additional measures become increasingly important, such as:



Figure 4-12. An aircraft rated ground fault interrupter from Textron Aviation.

- **De-energize Equipment:** Implement strict Lockout/Tagout (LOTO) procedures to ensure equipment is de-energized before entry. (covered later in this submodule).
- **Use Low Voltage:** Utilize extra low voltage equipment (e.g., 12 volt lighting).
- **Insulation and Barriers:** Use protective blankets, mats, or barriers to prevent accidental contact with energized parts.
- **Specialized Equipment:** Use non-conductive tools and lifelines which have low electrical conductivity versus traditional steel tools.
- **Training:** Ensure workers are trained to identify electrical hazards and to wear properly rated personal protective equipment.
- **Continuous Monitoring:** Use gas detectors to monitor for combustible gases that could be ignited by an arc.

POOR ACCESSIBILITY

Electrical hazards in aircraft with poor accessibility, particularly hidden wiring behind walls, pose major risks including system failures and in-flight fires. Inaccessible areas hinder maintenance and so often allow chafed, corroded or overheated wiring to go unnoticed which can lead to electrical failures, loss of critical flight instruments or ignition of fuel vapors. Two-thirds of wiring failures occur in areas where they cannot be detected before a failure. These issues include:

- **Undetected Degradation:** Wiring hidden behind walls, in floorboards, or in wing boxes cannot be easily inspected for age related cracking, corrosion, or insulation damage caused by heat and fluids.
- **In-Flight Fire Propagation:** Poor access makes it difficult for flight crews to reach ignition sources or effectively use fire extinguishers on wiring fires hidden in remote locations.
- **"Easy to Miss Maintenance Traps:** Limited visibility and cramped zones (e.g., wiring bundles) increase the risk of maintenance errors, such as "almost connected" pins that eventually fail.
- **Arc Fault Risks:** Compact wiring layouts with poor clearance make arc faults more likely, which can ignite nearby combustibles like lint or insulation.
- **Thermal Management:** Modern "more electric" aircraft (such as the Boeing 787) generate significant heat (up to 1.2 MW); poor access to these systems complicates cooling and monitoring, potentially leading to thermal runaway or battery fires.

PROTECTIVE MEASURES: PERSONAL PROTECTIVE EQUIPMENT (PPE), INSULATED TOOLS, SYSTEM ISOLATION

PREVENTION OF ELECTRIC SHOCK

Technicians can prevent electric shock and protect themselves by following these safe practices when working with electrical power tools, appliances, light fixtures and machinery.

POWER SOURCE CONSIDERATIONS

- **Inspect Power Cords -** Check power cords regularly and replace any that are frayed or have damaged insulation covers. Never tape or splice damaged cords. Occupational

safety and health standard requires that extension cords used with portable electric tools and appliances shall be of three wire type and shall be designed for hard or extra hard usage."

- Ground All Power Supplies - Ensure that all electrical equipment, electrical circuits, and power supply systems are grounded. Never remove the grounding wire on a three pronged cord. Never attach an ungrounded, two prong adapter plug to a three pronged cord or tool.
- Do Not Overload Circuits - Ensure that all circuit breakers or fuses have the correct rating.
- Always Use Ground Fault Circuit Interrupters (GFCIs) - GFCIs interrupt the flow of electricity within as little as 1/40 of a second. They can prevent electrocution in wet areas, such as sinks, or outdoors. Always follow the manufacturers' testing procedures to make sure GFCIs are working properly.
- Disconnect Electrical Equipment from Its Power Source Before Repairs - Never assume the electrical device has been unplugged. Check to make sure.

TOOLS AND EQUIPMENT

- Follow Manufacturer's Instructions - To avoid electrical shock, always use tools and equipment as intended and as outlined in the manufacturer's instructions.
- Inspect Tools Before Use - Ensure that all tools are in good working order before use. Remove from service any defective tool with a frayed cord, missing prongs, or a cracked casing. Attach a "Do Not Use" tag to the damaged tool. Set it aside and report it to a supervisor. Allow only a qualified electrician to complete repairs.
- Never Use Electric Appliances or Tools Near Water. Avoid all liquids when using electrical devices. Even the water content in the human body can make an efficient conductor of electricity when it seeks a path to the ground.
- Use Double Insulated Tools - Tools with non-metallic cases and a manufacturer's label that says "double insulated" means the insulation is inside the tool. This insulation protects the user from shock if water enters the tool's housing. If a double insulated tool is dropped into water, disconnect the power source before reaching for it.
- Keep Tools and Equipment Clean - Clean and inspect tools after each use. Liquids, such as grease, oil, and solvents left on tools and equipment can result in electric shock.

PPE FOR ELECTRIC SHOCK

Wear rubber soled shoes and insulated gloves when operating power tools, replacing fuses or working with any device that could give an electric shock. Use rubber floor matting if available. Insulating rubber gloves are often rated and color tagged identifying the degree of protection they will provide for various voltages. [Figure 4-13]

FIRST AID FOR ELECTRIC SHOCK

An electric shock is a medical emergency that occurs when the body completes an electrical circuit, leading to symptoms such as burns, muscle spasms, difficulty breathing and potential cardiac arrest. Immediate medical help is crucial.

Voltage Classifications for Rubber Gloves			
Tag Color	Class	Proof Test Voltage AC/DC	Max. Usage Voltage AC/DC
Beige	00	2,500/10,000	500/750
Red	0	5,000/20,000	1,000/1,500
White	1	10,000/40,000	7,500/11,250
Yellow	2	20,000/50,000	17,000/25,500
Green	3	30,000/60,000	26,500/39,750
Orange	4	40,000/70,000	36,000/54,000

Figure 4-13. Insulating gloves can offer protection from voltages up to 54 000 volts DC.

In all cases, the first action when a coworker is subject to electric shock is to turn off the power source, either by a switch, a circuit breaker or by unplugging the device. If this is not possible use a dry non-conductive item, such as wood or plastic to move the source or the victim away. Never touch the person while they are in contact with electricity. Once this is assured, immediately call for emergency medical help. [Figure 4-14]

While waiting for their arrival, check if the person is breathing or has a pulse. If they are not breathing begin cardiopulmonary resuscitation (CPR) if you are so trained. If burns are evident, cover with sterile non-stick bandages or a clean cloth. Do not use blankets or towels. If breathing is present but faint, lay the victim down with legs elevated and keep them warm.

PPE FOR ARC FLASH

IEC/EN 61482 is a standard developed by the International Electrotechnical Commission (IEC) for protective clothing to shield technicians from the thermal hazards of an electric arc and so limiting or eliminating the possibility of second degree burns during an arc flash event at various energy levels. This standard ensures that clothing materials and garments provide sufficient insulation and do not ignite, melt, or break open when exposed to the heat and energy of an arc flash.

Arc flash intensity, and so the need for protective equipment is described in four categories based on the calories of heat per cm² of possible exposure. [Figure 4-15]

- Category 1 (up to 4 cal/cm²)
Requires arc resistant (AR) long sleeve shirt and pants or coveralls, hard hat, safety glasses, hearing protection, AR face shield or suit hood, heavy duty leather gloves, and leather footwear.
- Category 2 (up to 8 cal/cm²)
Requires AR long sleeve shirt and pants or AR coverall, hard hat, safety glasses, hearing protection, AR flash suit hood or face shield with balaclava, heavy duty leather gloves, and leather footwear.
- Category 3 (up to 25 cal/cm²)
Requires a full AR flash suit system (jacket and pants

or coveralls), AR flash suit hood, AR gloves or rubber insulating gloves with leather protectors, hard hat, safety glasses, hearing protection, and leather footwear.

- Category 4 (up to 40 cal/cm²)
Requires a full AR flash suit system (jacket and pants or coveralls), AR flash suit hood, AR or rubber insulating gloves with leather protectors, hard hat, safety glasses, hearing protection, and leather footwear.

Many maintenance operations frequently encounter situations where Category 1 and Category 2 levels are common during maintenance and troubleshooting tasks on aircraft electrical systems and ground support equipment.

While aircraft systems operate at various voltages, most general aviation aircraft run on 28 volt DC or 115/200 volt AC power which often result in lower incident levels compared to heavy industrial power systems. However the type of equipment being maintained, for example ground power units, avionics bays, battery systems and generators and their specific configurations affect



Figure 4-14. Never touch a person exposed to electricity. Use a non-conductive (wood) rod to separate them from the electrical source.

the potential hazard. In addition, working within confined spaces and in the presence of conductive materials increase the risk and so must be accounted for.

While specific categories depend on the arc flash risk assessment, the typical PPE worn by aviation engineers for electrical work includes:

- Arc-rated long sleeve shirts, pants or coveralls meeting at least a category 1 or 2 rating.
- Safety glasses or goggles.
- Hard hats with an integrated arc rated face shield
- Hearing protection.
- Heavy duty leather gloves.
- Non-conductive safety toe footwear.

In aviation maintenance, tasks requiring the higher arc flash PPE categories 3 and 4 are less common but can occur during specific high voltage operations. These tasks typically involve:

- Working on high voltage ground support equipment: Maintenance on large, high powered ground power units can involve significant energy levels, especially when troubleshooting energized components.
- Maintenance of specific high voltage aircraft systems: Some larger modern aircraft utilize higher voltage systems in power generation or distribution. Working on these exposed parts can require a higher category of protective equipment.
- Removal of bolted covers on high energy panels: Actions that might disturb components in a high energy panel, such as removing a bolted cover are considered high risk activities that could necessitate Category 3 or 4 protective equipment.
- Working in confined spaces: Performing electrical work in confined spaces, such as an aircraft's electrical or avionics bays can concentrate the energy of an arc flash event, potentially pushing the required protective equipment into a higher category.

PPE CATEGORY 1	PPE CATEGORY 2	PPE CATEGORY 3	PPE CATEGORY 4
<p>Minimum Arc Rating of 4 cal/cm²</p> <p>Arc Rated Clothing:</p> <ul style="list-style-type: none"> • AR long-sleeve shirt and pants, or AR coverall • AR face shield, or AR flash suit hood • AR jacket, parka, rainwear, or hard hat liner (as needed) <p>Protective Equipment:</p> <ul style="list-style-type: none"> • Hard hat • Safety glasses or safety goggles • Hearing protection (with inserts) • Heavy-duty leather gloves • Leather footwear (as needed) 	<p>Minimum Arc Rating of 8 cal/cm²</p> <p>Arc Rated Clothing:</p> <ul style="list-style-type: none"> • AR long-sleeve shirt and pants, or AR coverall • AR flash suit hood, or AR face shield and AR balaclava • AR jacket, parka, rainwear, or hard hat liner (as needed) <p>Protective Equipment:</p> <ul style="list-style-type: none"> • Hard hat • Safety glasses or safety goggles • Hearing protection (with inserts) • Heavy-duty leather gloves • Leather footwear 	<p>Minimum Arc Rating of 25 cal/cm²</p> <p>Arc Rated Clothing:</p> <ul style="list-style-type: none"> • As required: AR long-sleeve shirt, AR pants, AR coverall, AR flash suit jacket, and/or AR flash suit pants • AR flash suit hood • AR gloves • AR jacket, parka, rainwear, or hard hat liner (as needed) <p>Protective Equipment:</p> <ul style="list-style-type: none"> • Hard hat • Safety glasses or safety goggles • Hearing protection (with inserts) • Leather footwear (as needed) 	<p>Minimum Arc Rating of 40 cal/cm²</p> <p>Arc Rated Clothing:</p> <ul style="list-style-type: none"> • As required: AR long-sleeve shirt, AR pants, AR coverall, AR flash suit jacket, and/or AR flash suit pants • AR flash suit hood • AR gloves • AR jacket, parka, rainwear, or hard hat liner (as needed) <p>Protective Equipment:</p> <ul style="list-style-type: none"> • Hard hat • Safety glasses or safety goggles • Hearing protection (with inserts) • Leather footwear (as needed)

Figure 4-15. The type of arc flash protective clothing required is dependent on the potential severity of the blast.

- Specific battery maintenance operations: While routine battery checks are low risk, maintenance involving large, high capacity battery systems (e.g., lithium ion batteries in some modern aircraft) where a fault could lead to a high current discharge may require higher levels of protection.
- Testing or troubleshooting that requires exposed energized parts: Any task where a worker must interact with bare live electrical conductors and circuit parts can escalate the PPE requirements.

LOCKOUT/TAGOUT (LOTO)

Lockout/Tagout (LOTO) is a critical safety protocol ensuring aircraft systems (electrical, hydraulic, pneumatic, etc.) are fully de-energized and secured with locks and tags during maintenance, in order to prevent an accidental startup, system release, or energy surge that could injure workers or damage the aircraft.

This procedure is mandatory for all personnel servicing aircraft. It involves identifying energy sources, releasing stored energy, shutting down and/or isolating equipment such as breakers and valves and locking/tagging the devices to prevent a restart.

THE LOCKOUT/TAGOUT PROCESS

The process involves two main actions. First there is lockout. This means physically locking energy isolating devices like switches and circuit breakers in the off position. This ensures they can not be operated while maintenance is ongoing.

Second is tagout. This involves attaching physical warning tags to these devices. These tags indicate that maintenance work is in progress and the equipment should not be energized. [Figure 4-16]

Before any maintenance begins, the team identifies the systems and equipment they will work on. They consult job cards and maintenance manuals to insure they know what they are dealing with. The responsible technician or supervisor then isolates the

energy sources by locking and tagging the appropriate controls. This step also includes dissipating any stored energy such as residual hydraulic pressure or electrical charge.

If the maintenance work takes longer than a single shift, the lockout/tagout devices and tags must stay in place until the work is completed. This ensures that everyone involved knows that the equipment is still under maintenance. If multiple technicians are working on the same systems, each can apply their own tags. This clear communications is essential for safety. Once the maintenance is finished, the mechanic or supervisor removes the lockout/tagout devices and files the documentation in the control log. They also check that all systems are back to their normal operating condition before the aircraft is released from maintenance.

EIGHT STEPS OF LOCKOUT/TAGOUT

An aviation LOTO process follows these eight steps:

1. Preparation: Identify all energy sources (electrical, hydraulic, etc.) using aircraft maintenance manuals.
2. Notification: Inform all "affected" employees—those working in or around the area—that systems will be locked out.
3. Shutdown: Power down the aircraft systems according to standard procedures.
4. Isolation: Physically separate the equipment from its energy sources (e.g., pulling breakers or closing valves).
5. Application of Devices: Attach authorized locks and tags to each isolation point.
6. Control Stored Energy: Relieve residual pressure in hydraulic lines or discharge electrical capacitors.
7. Verification: Attempt to operate the system to confirm it is truly de-energized (often called the "Tryout").
8. Restoration: After work is complete, only the person who applied the lock may remove it and return the system to service.

To facilitate the lockout/tagout process, a lockout/tagout kit is commonly available within a maintenance facility. This kit contains both locking mechanisms and warning labels for multiple devices and system types. [Figure 4-17]

VERIFICATION OF ABSENCE OF VOLTAGE

Verifying the absence of voltage is a critical, mandatory safety procedure to ensure equipment is de-energized before maintenance, preventing electrical shock and arc flash. It involves testing for voltage using calibrated equipment, such as an Absence of Voltage Tester (AVT) or a handheld meter on all electrical phases and ground. [Figure 4-18]

THE "LIVE-DEAD-LIVE" METHOD

The live-dead-live method is the standard procedure when using handheld volt meters and multimeters to ensure that both voltage is absent and the instrument is working correctly. This test has three steps.

- Live: Test the meter on a known energized source (of similar voltage and type) to confirm it is functioning.
- Dead: Test the circuit intended for work. You must check phase-to-phase and phase-to-ground for all conductors to ensure no backfeeds or remaining potentials exist.



Figure 4-16. A circuit breaker panel with the system undergoing maintenance clearly tagged and locked out.

- Live: Immediately re-test the meter on the known energized source to verify it didn't fail during the process.

Some important concerns when using this method are:

1. Always use proper personal protective equipment while testing until the absence of voltage is verified. In all cases, the system must be treated as fully energized until it is proven not to be.
2. You must test both phase to phase and phase to ground. Testing only phase to phase can lead to a false-safe reading if multiple phases are being back fed from the same source.
3. Your testing instrument must be adequately rated for the system voltage and category

ABSENCE OF VOLTAGE TESTER (AVT)

An Absence of Voltage Tester is a permanently mounted and acceptable device that automates the process of verifying that a circuit is de-energized by allowing users to confirm the absence of voltage before opening electrical enclosures. The procedure typically operates through a built in test button. When engaged a green light indicates the absence of voltage while a red light indicates voltage is present. [Figure 4-19]

If the system and components do not contain such a device, the above live-dead-live method must be used.

ADDITIONAL ELECTRICAL SAFETY STANDARDS

Additional information regarding electrical safety standards beyond those specific to the aviation environment can be found through these documents:

- EU Directive 2006/42/EC - Machinery Directive
Covers general requirements for the safety of machinery and electrical equipment. Specifically Annex 1 - 1.5.9 which requires that electrical equipment must be protected against electrical risks during operation, maintenance and transport.
- EN50110 - Operation of Electrical Installations
The established EU standard for safe work on electrical installations. Covers risk assessment, shielding/zoning, LOTO, voltage control, the use of PPE, procedures for dead working,
- IEC/EN 61482 - Arc Flash Protective Clothing
Describes material requirements and certification standards for clothing that protects against arc flash.
- Swedish ELSAK-FS 2008:1
Requirements for electrical safety work addresses systematic electrical safety work, risk assessment, routines, competence requirements.
- Swedish ELSAK-FS 2007:1
Installation rules including which parts require a voltage free environment and steps for safe installation.



Figure 4-17. A typical lockout/tagout kit, contains multiple locking device styles and warning tags.

Verifying the Absence of Voltage

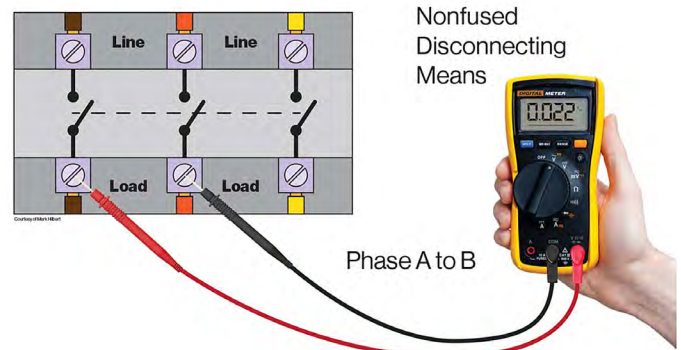

Figure 4-18. Using a voltmeter/ multimeter to verify the absence of voltage.



Figure 4-19. An Absence of Voltage Tester, if installed in the system or component is an acceptable and fast way to determine that the system is deenergized.

This page was intentionally left blank.

SUBMODULE 4 PRACTICE QUESTIONS

Question 4-1

In what way does a humid environment increase the possibility of arc flash?

Question 4-2

What is the most important step which can be taken during maintenance to reduce the possibility of arc flash?

Question 4-3

Name a common aviation maintenance task which would require the use of Category 4 protective clothing.

Question 4-4

What three factors determine the severity of an electrical shock?

Question 4-5

What is signified by beige colored rubber gloves?

Question 4-6

For what situation(s) would a double insulated tool be necessary?

Question 4-7

What is your first consideration should you encounter a coworker subjected to electric shock?

Question 4-8

What is the primary reason for Lockout/Tagout procedures?

Question 4-9

During what aviation procedure is the risk of electrostatic discharge the greatest?

Question 4-10

In what way can a capacitor be kept safe from recovering its charge during storage?

SUBMODULE 4 PRACTICE ANSWERS

Answer 4-1

Humidity, particularly in coastal areas, promotes corrosion which will degrade electrical connectors and insulation.

Answer 4-2

Shut off (de-energize) power to the related equipment.

Answer 4-3

Removal or installation of bolted covers on a high energy panel.

Answer 4-4

The amount of current, the path of current through the body and the duration of the exposure.

Answer 4-5

Beige colored rubber gloves, or Class 00 are the lightest class of protection from electric shock and suitable only for voltages below 500 volt AC or 750 volt DC.

Answer 4-6

When there is a possibility of water entering the tool housing such as when working in the rain or if there is a possibility of dropping the tool in water.

Answer 4-7

Is the person still in contact with electricity?

Answer 4-8

That a coworker will not re-energize a component while it is undergoing maintenance.

Answer 4-9

During fueling and defueling the aircraft. Always be sure both the aircraft and fueling station such as a truck is fully grounded before beginning this procedure.

Answer 4-10

Always insure that a capacitor is kept shorted during storage by installing a jumper between the terminals.